

DEFINITION OF TERMS

Term	Definition
Monitor description	Description of what the ECM monitors and how it detects malfunctions (monitoring purpose and its details).
Related DTCs	A group of diagnostic trouble codes that are output by the ECM based on the same malfunction detection logic.
Typical enabling conditions	Preconditions that allow the ECM to detect malfunctions. With all preconditions satisfied, the ECM sets the DTC when the monitored value(s) exceeds the malfunction threshold(s).
Sequence of operation	The priority order that is applied to monitoring, if multiple sensors and components are used to detect the malfunction. While one sensor is being monitored, the next sensor or component will not be monitored until the previous monitoring has been completed.
Required sensor/components	The sensors and components that are used by the ECM to detect malfunctions.
Frequency of operation	The number of times that the ECM checks for malfunctions per driving cycle. "Once per driving cycle" means that the ECM detects the malfunction only one time during a single driving cycle. "Continuous" means that the ECM detects the malfunction every time the enabling conditions are met.
Duration	The minimum time that the ECM must detect a continuous deviation in the monitored value(s) before setting a DTC. This timing begins after the "typical enabling conditions" are met.
Malfunction thresholds	Beyond this value, the ECM determines that there is a malfunction and sets a DTC.
MIL operation	MIL illumination timing after a defect is detected. "Immediate" means that the ECM illuminates the MIL the instant the ECM determines that there is a malfunction. "2 driving cycles" means that the ECM illuminates the MIL if the same malfunction is detected again in a 2nd driving cycle.
Component operating range	Normal operation range of sensors and solenoids under normal driving conditions. These ranges are for a reference. They cannot be used to determine whether a sensor or solenoid is defective or not.

PARTS LOCATION

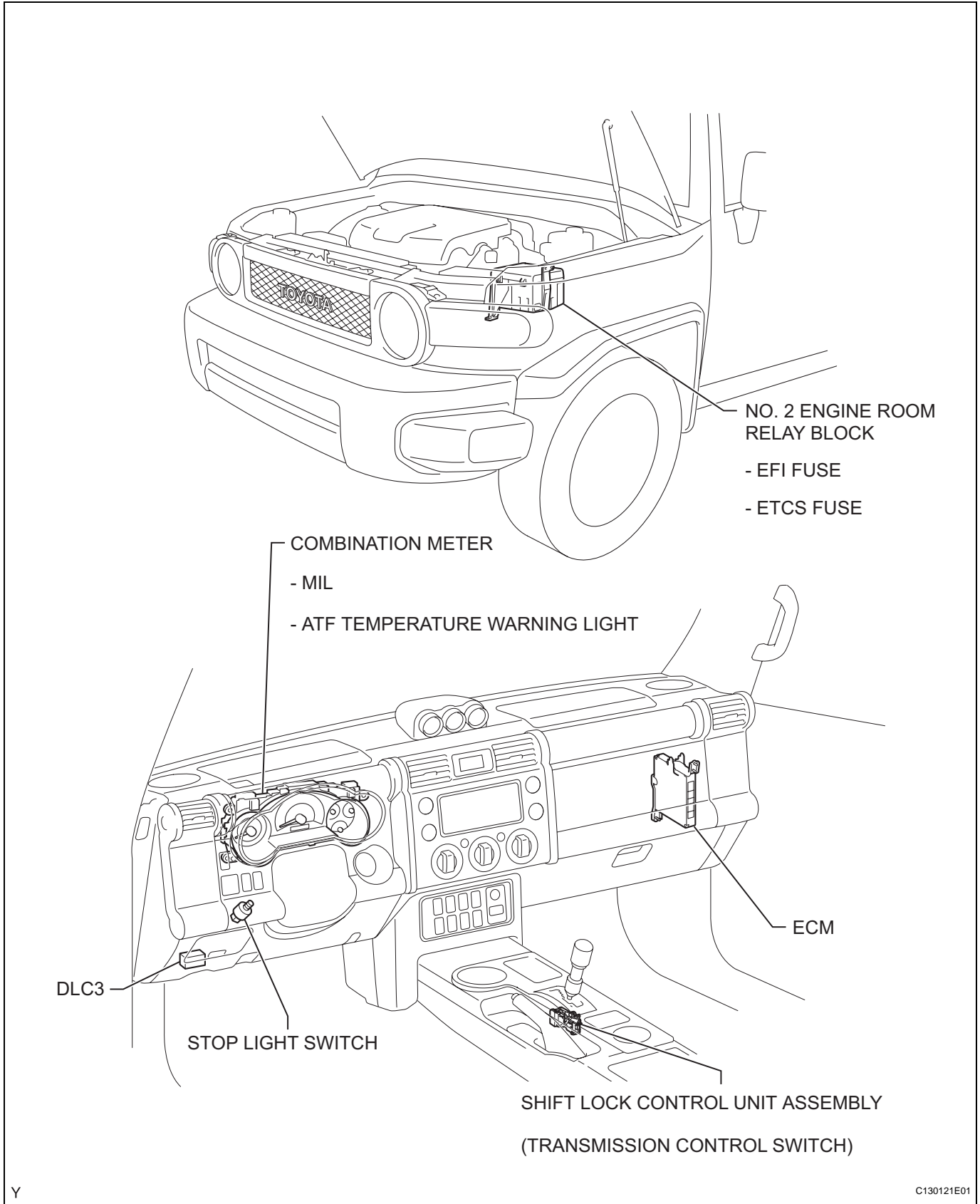

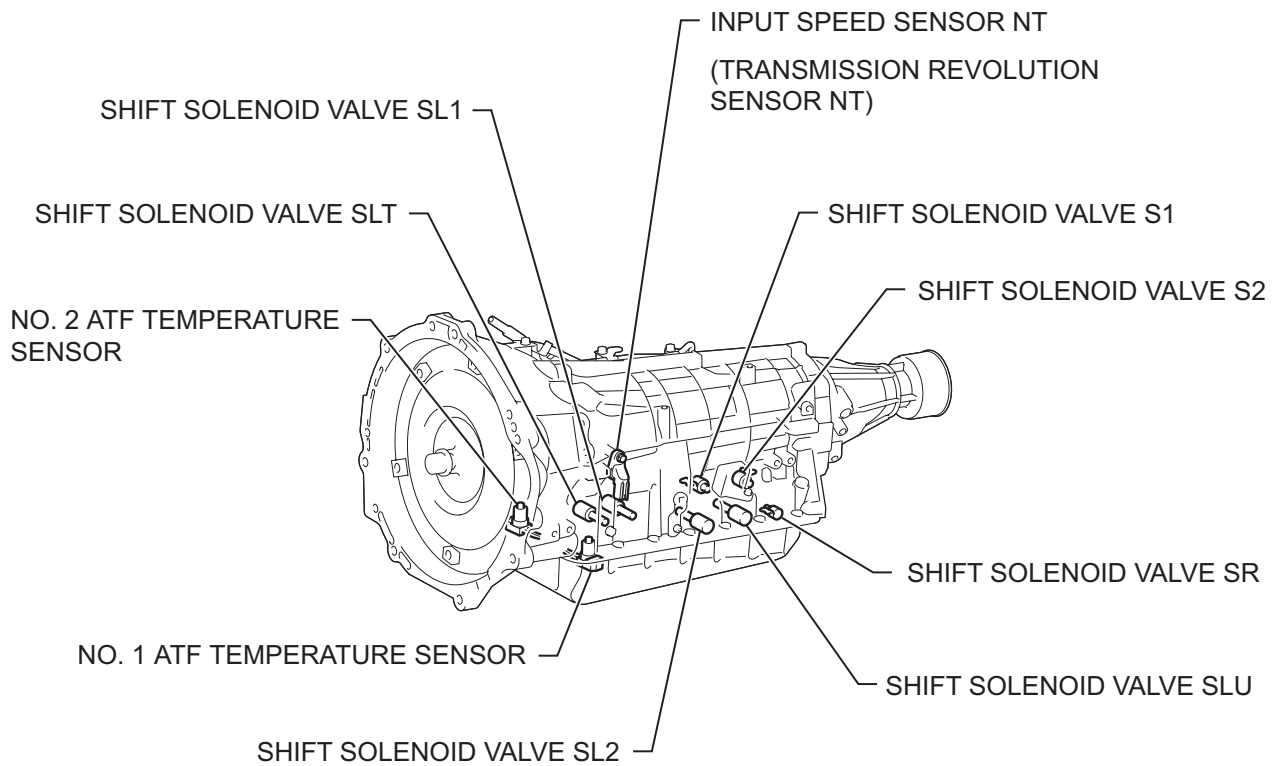
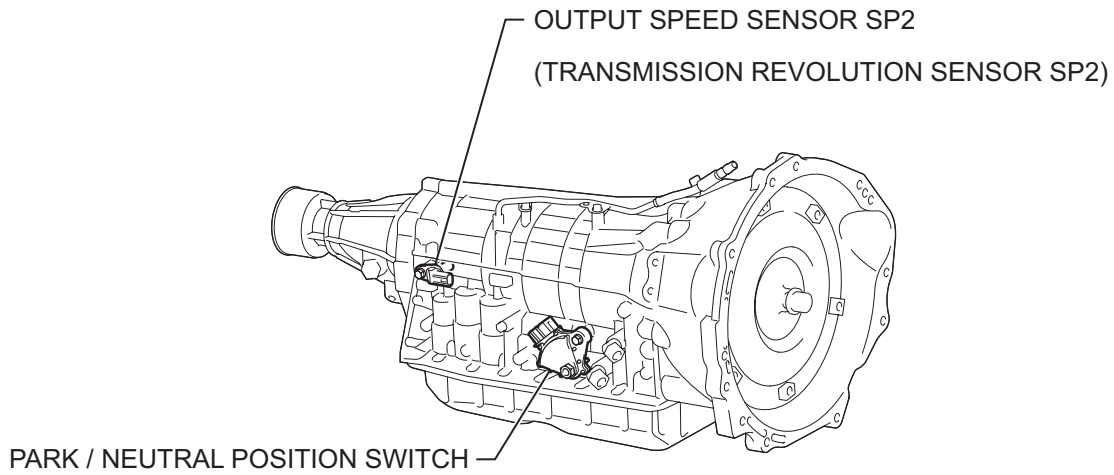

AT